

# Gutter Installation Guide

ACME Sheet Metals

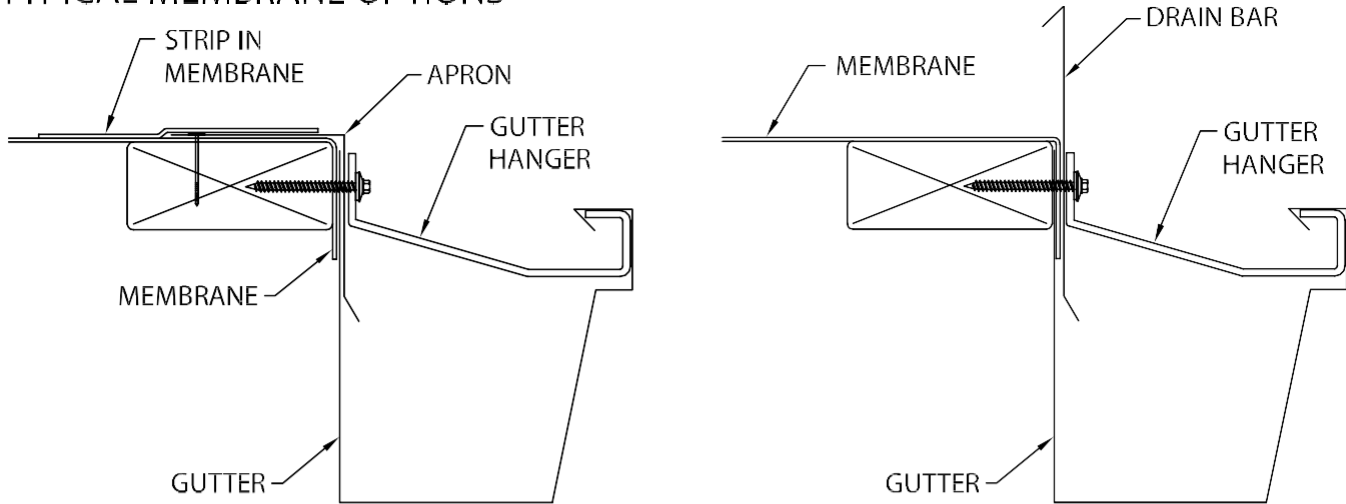

## TYPICAL MEMBRANE OPTIONS



---

## STEP 1. MEMBRANE INSTALLATION

REVIEW CAREFULLY AND FOLLOW PRIMARY ROOF MATERIAL MANUFACTURER'S RECOMMENDATIONS, AND ARCHITECT'S DETAILS FOR INSTALLING ROOF MEMBRANE IN CONJUNCTION WITH THIS GUTTER SYSTEM.

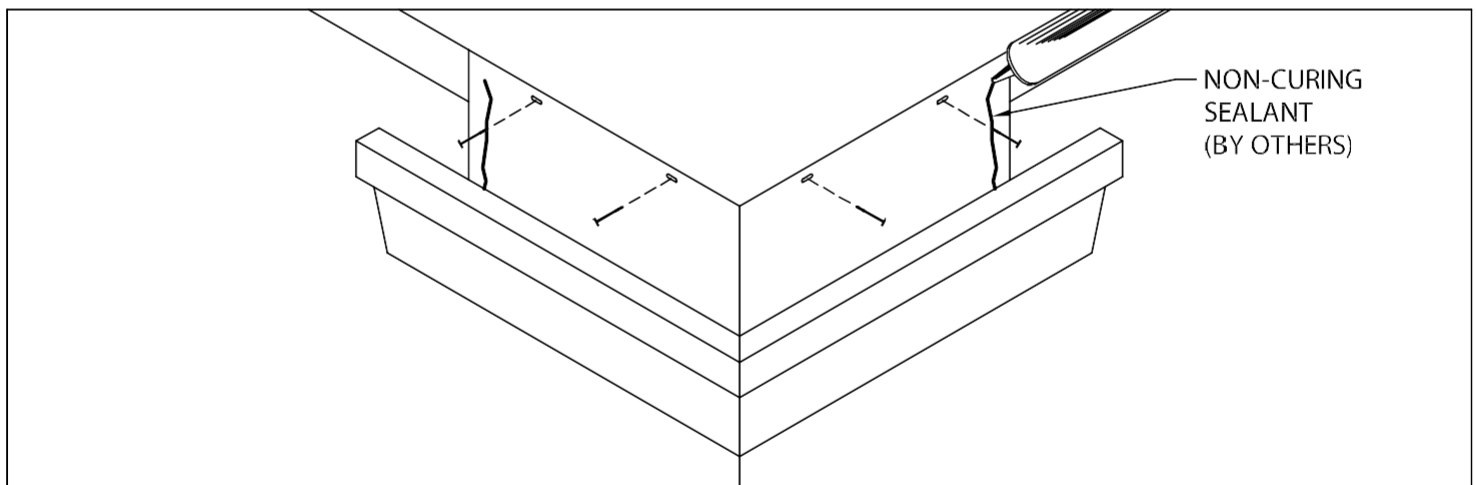

## STEP 2. MITER INSTALLATION

INSTALL MITERS AT LOCATIONS SHOWN ON PLANS. FASTEN TO NAILER THROUGH PRE-SLOTTED HOLES 12" O.C. USING PROVIDED 1/4" GALVANIZED ROOFING NAILS. APPLY A HEAVY BEAD OF NON-CURING SEALANT TO THE INSIDE OF EACH MITER END AS SHOWN.

# Gutter Installation Guide

ACME Sheet Metals

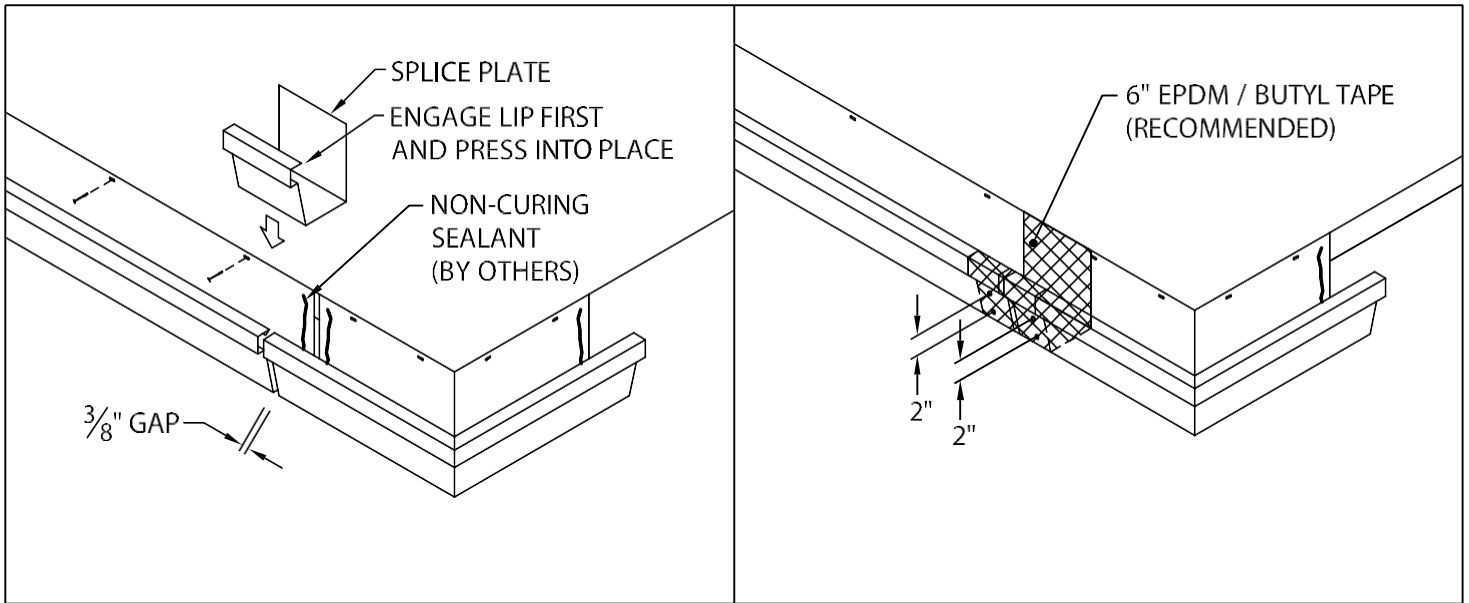

## STEP 3. GUTTER INSTALLATION

INSTALL GUTTER SECTIONS FROM RIGHT TO LEFT AS SEEN FROM ROOF. APPLY A HEAVY BEAD OF NON-CURING SEALANT TO INSIDE LENGTH OF GUTTER. LEAVE A  $\frac{3}{8}$ " GAP AT SPLICE JOINT. PLACE A 6" WIDE SPLICE PLATE AT JOINT. RIVET SECTIONS WITH PROVIDED  $\frac{1}{8}$ " STAINLESS STEEL POP RIVETS AT SPLICE JOINT 2" O.C. AS SHOWN. NAIL GUTTER SECTIONS TO NAILER AT 12" O.C. USING PROVIDED  $\frac{1}{4}$ " GALVANIZED ROOFING NAILS. METAL-ERA RECOMMENDS THE APPLICATION OF EPDM / BUTYL PRESSURE SENSITIVE TAPE CENTERED OVER THE SPLICE PLATE AND LAPPING THE GUTTER SECTIONS A MINIMUM OF 1"

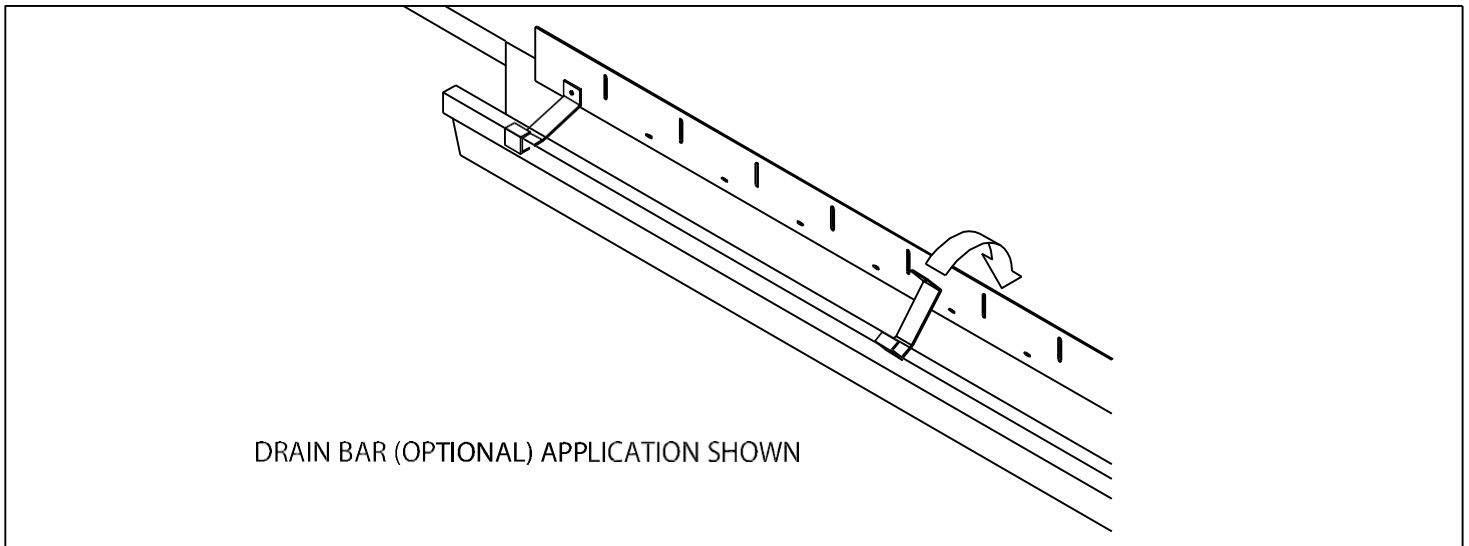

## STEP 4. HANGER INSTALLATION

HOOK HANGER UNDER LEADING EDGE OF GUTTER AND ROTATE INTO PLACE. FASTEN HANGER 30" O.C. USING PROVIDED #10 x 2" STAINLESS STEEL FASTENERS THROUGH BACK SIDE OF GUTTER INTO WOOD NAILER.

# Gutter Installation Guide

ACME Sheet Metals

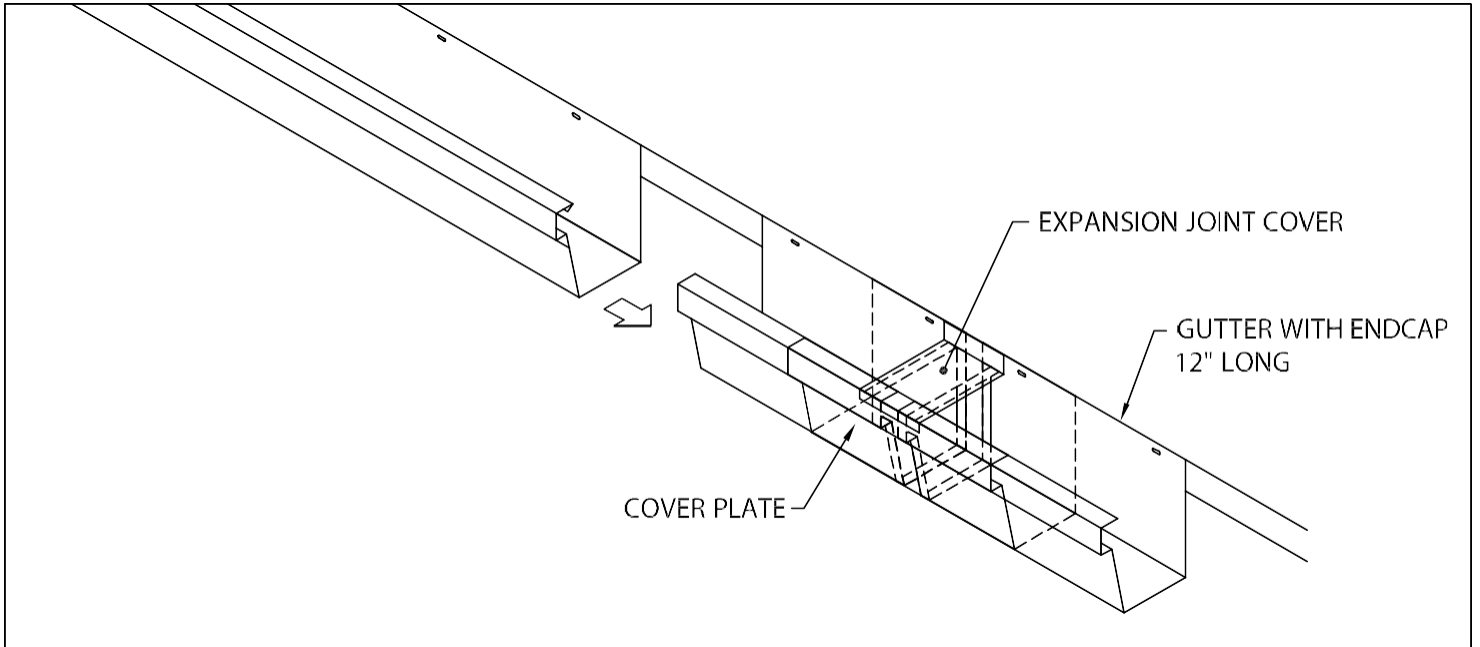

## STEP 5. EXPANSION JOINT INSTALLATION (WHERE NECESSARY)

INSTALL EXPANSION JOINTS IN LOCATIONS AS SPECIFIED ON ROOF PLANS OR AT A MAXIMUM OF 48'-0" O.C. NAIL INTO PLACE AND INSTALL SPLICE PLATE AS PER STEP #3.

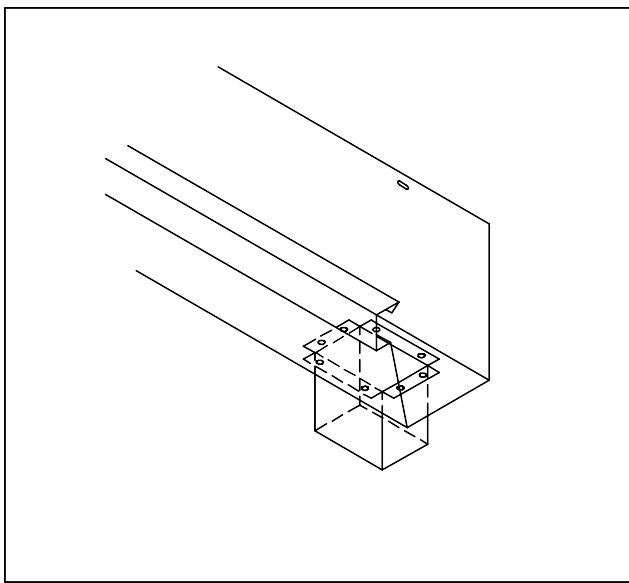

## STEP 6. OUTLET INSTALLATION

DETERMINE OUTLET LOCATIONS AND FIELD CUT HOLE IN A NEAT WORKMANLIKE MANNER. INSERT ALUMINUM OUTLET, FASTEN WITH PROVIDED  $\frac{1}{8}$ " STAINLESS STEEL POP RIVETS, TWO RIVETS IN EACH FLANGE AND SEAL WITH NON-CURING SEALANT.

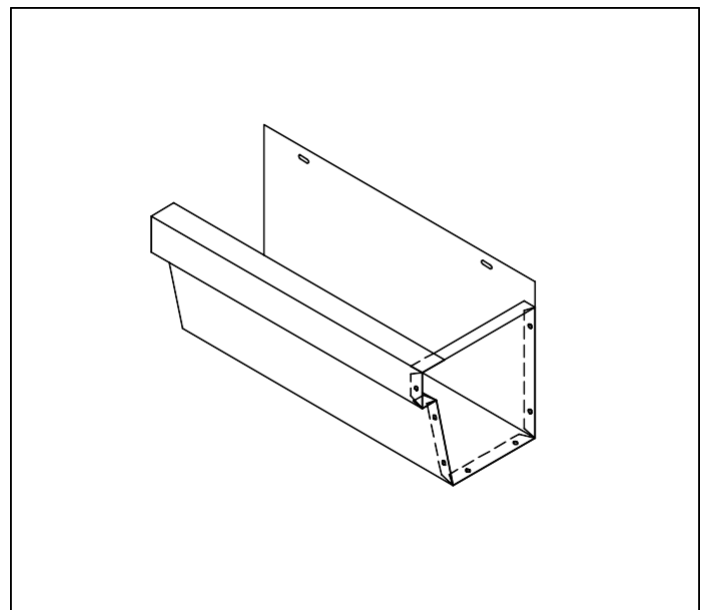

## STEP 7. END CAP INSTALLATION

INSTALL ENDCAPS AT ALL TERMINATIONS. FIELD RIVET WITH PROVIDED  $\frac{1}{8}$ " STAINLESS STEEL POP RIVETS AT 2" O.C. AND SEAL WITH NON-CURING SEALANT

# Gutter Installation Guide

ACME Sheet Metals



- 1 CUT A 12'-0" SECTION OF THE GUTTER INTO (2) 6'-0" PIECES. (THE EXPANSION JOINT IS DESIGNED TO FIT BETWEEN THE (2) 6'-0" SECTIONS).

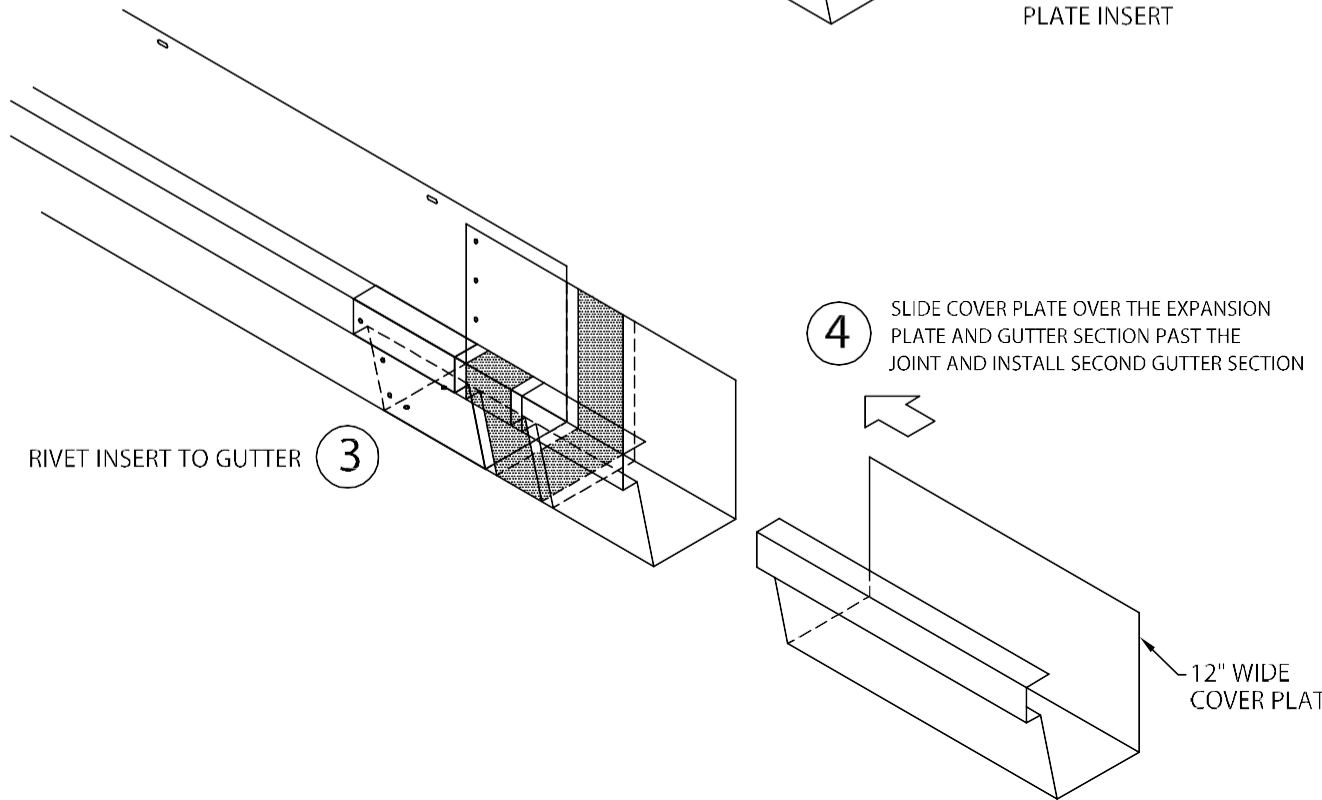
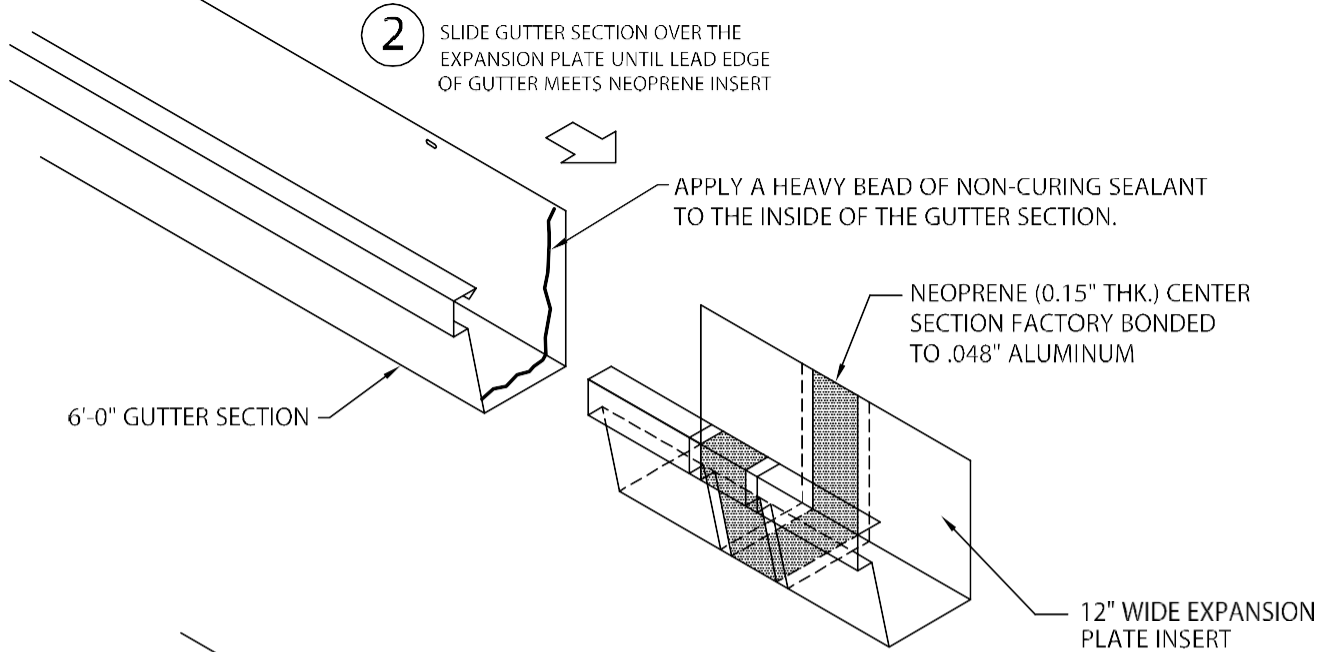

# Gutter Installation Guide

ACME Sheet Metals

